

FIGURE 1
Elevation View

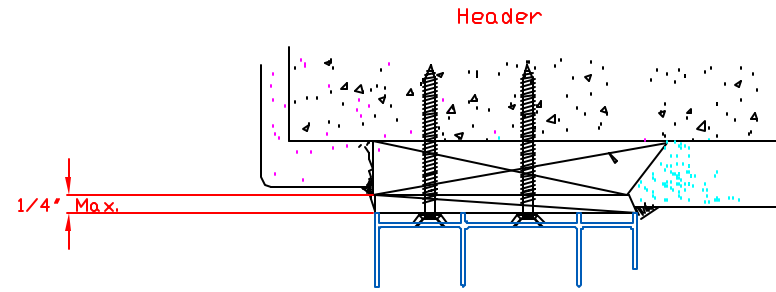

FIGURE 3
Elevation View

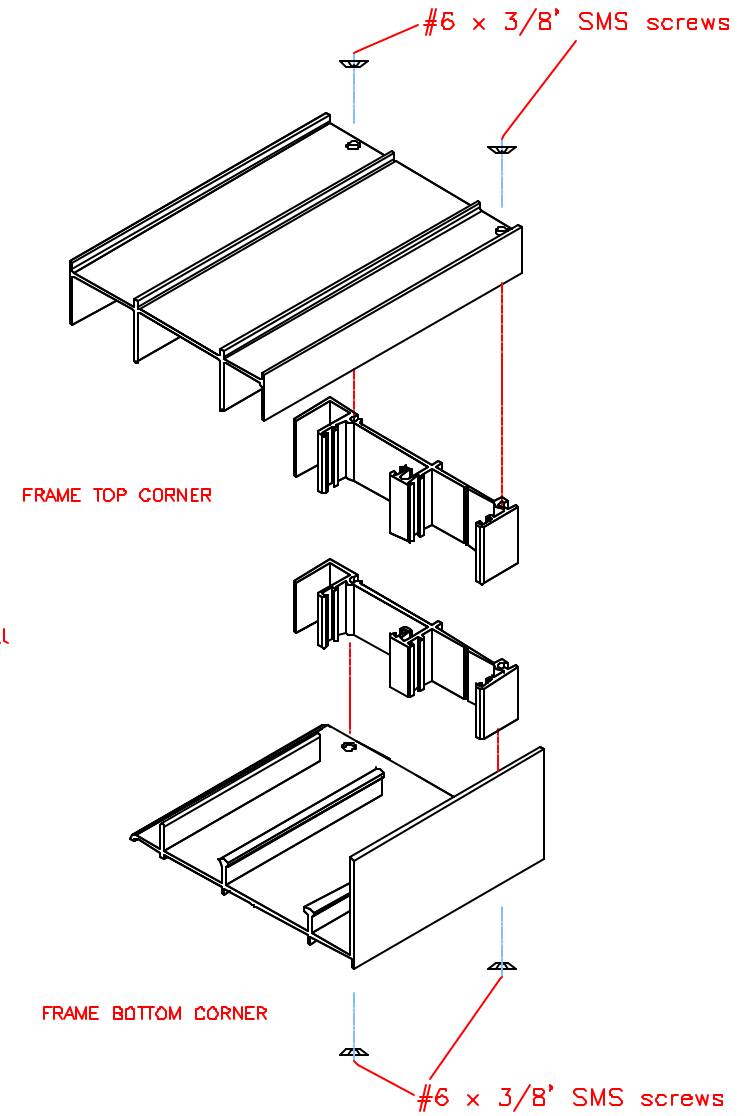

FIGURE 4

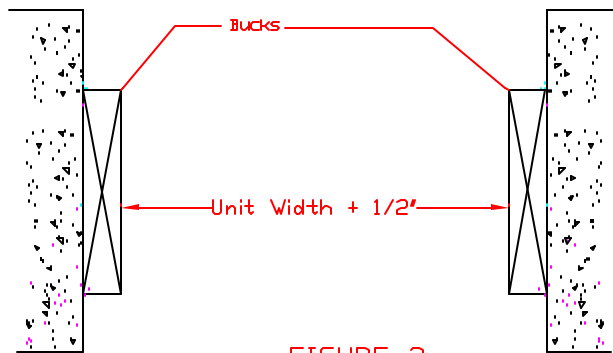
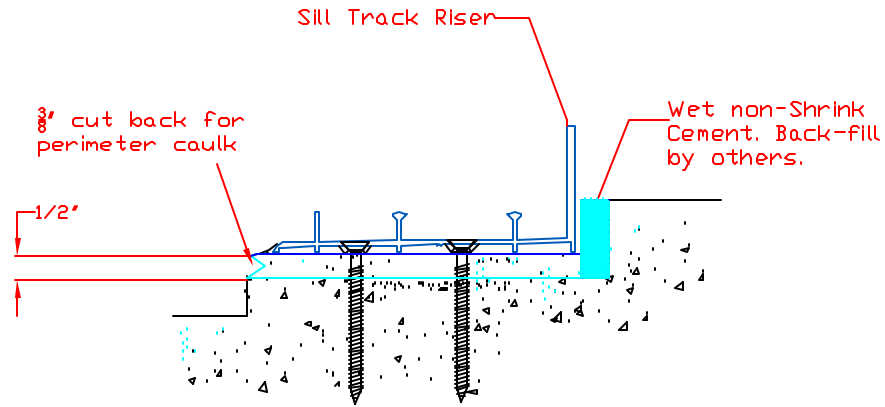

FIGURE 2
Plan View



Revision Note:			LAWSON INDUSTRIES, INC.		B501 N.W. 90 ST. MEDLEY, FLORIDA 33166 PH No. (305) 886-8660	
Perimeter	Area	Wt./Lb.	Drawn	Part Class	Prod. Category	Series/Model
0.000	0.000	0.000	---	---	---	---
Material	Surface Area	Est. Cost	Drawn Date	Part Class	Prod. Category	Series/Model
---	0.000	0.000	06/01/06	---	---	---
As-m	Sp-s	C	Drawn Date	Part Class	Prod. Category	Series/Model
0.000	0.000	0.000	06/01/06	---	---	---
Drawn By	Drawn Date	Drawn Date	Drawn Date	Part Class	Prod. Category	Series/Model
---	---	06/01/06	---	---	---	---
Check By	Check Date	Check Date	Check Date	Part Class	Prod. Category	Series/Model
---	---	---	---	---	---	---
Factor	Cost	Scale	Part Number	Drawing Number	Revision Level	
000	0.000	1/8	---	---	---	

LAWSON
INDUSTRIES, INC.

MANUFACTURER OF QUALITY ALUMINUM WINDOWS AND GLASS DOORS

FRAME INSTALLATION SLIDING GLASS DOORS

FRAME INSTALLATION - SLIDING GLASS DOORS

Preliminary to installation

- A- Open frame package, and inspect all components against parts list for count and accuracy.
- B- Measure the length of track and headers, they should be the same length, and equal to unit width.
- C- Check buck opening width, and height in at least three places. Buck width should equal unit width + 1/2". Buck height should equal unit height + 3/4". See figures # 1 and 2.
- D- Inspect wood bucks to ensure they are back-bedded to masonry.
- E- Jamb bucks must terminate 1/2" above floor level. No part of the jamb buck can extend down into floor depression. See fig. #1.
- F- Bucks must be securely anchored to masonry, and attachment must comply with building code.
- G- Floor depression (recess) must be at least 1 1/2" deep, and free of obstructions.
- H- If second floor installation, and or wood frame installation on ground floor, a sill pan must be provided. See paragraph #12.

INSTALLATION PROCEDURES

- 1- Assemble both jambs to header, and track using 2 #6x3/8" PH. S.M.S.per corner. Narrow screen jambs must face exterior. Narrow space between header fin, and fascia fin must face interior. Fig.#4
- 2- Seal front and backside of jamb to track, and upstanding track riser using seam sealer or A.A.M.A. approved caulk. If acceptable to customer, it is highly recommended to seal front side of jamb to track as well.
- 3- Lay a bed of premixed wet non-shrink cement into depression. Move cement side-to-side, and back to front. Push cement against vertical back of depression. Leave space at both ends of track which will later be filled with A.A.M.A.approved caulk. Fill all honeycomb brackouts, and trowel from lowest point until bed is level, and approximately 3/4" deep. A quick set concrete accelerator is suggested to promote a speedy set up. If not used, allow at least 1-1/2 hours time lapse before attempting to anchor track.
- 4 Stand frame up in opening, and lower frame down until track is laying in wet cement. Move frame latterly to create equal space between both jambs and bucks. Center frame on bucks. Any space between track riser and wall of floor depression is to be filled by others. Fig#3 Note: Top of door track riser must not extend more than 3/4" above rough floor surface.
- 5- Place level on track, and using mallet, tap track down evenly until track sinks approximately 1/4" into wet cement. Trowel off excess. A 1/4" space will now exist between the header and header buck. A space in excess to 1/4" will not comply with code. See Fig. #4
- 6- Recheck sill for level condition. Plumb jambs. Check width and height in at least three places. Use "story pole" (1"x2" aluminum tube cut to jamb height) to gauge proper unit height along entire width of unit.
- 7- Place shims between buck, jamb and header at all anchoring points. Anchor with flat head concrete screws, passing through coined holes in frame, through buck and 1 1/4" deep into masonry.
- 8- Cut 3/8" groove at nose of track. Groove will be filled (by others) at the perimeter caulking stage. Refer to Lawson "General Door waterproofing practice # " for suggested sealing of opening.
- 9- Seal all fastener heads, and any small manufacturing holes in jambs.
- 10- Install header and track pressure sensitive weather pads at centerline of interlocks, and at center of opening on OXXO units.
- 11- Prior to stucco application, it is strongly recommended to spray a low expansion foam into all cavities existing between the door frame, bucks and masonry. A polyurethane or approved equal material is suggested. This procedure will provide long lasting benefit i.e.: (this application is not by door installer)
 - A - Reduce noise transmission
 - B- Provide additional solid support of frame
 - C - Reduces possibility of water or moisture penetration
 - D - Reduces air movement
 Please refer to Lawson water proofing detail for additional sealing suggestings.
- 12- Sill Pans (flashing) must be provided for all wood frame installation, and or second floor masonry construction when a conventional floor depression does not exist. Refer to Lawson sill panel detail for proper fabrication details.

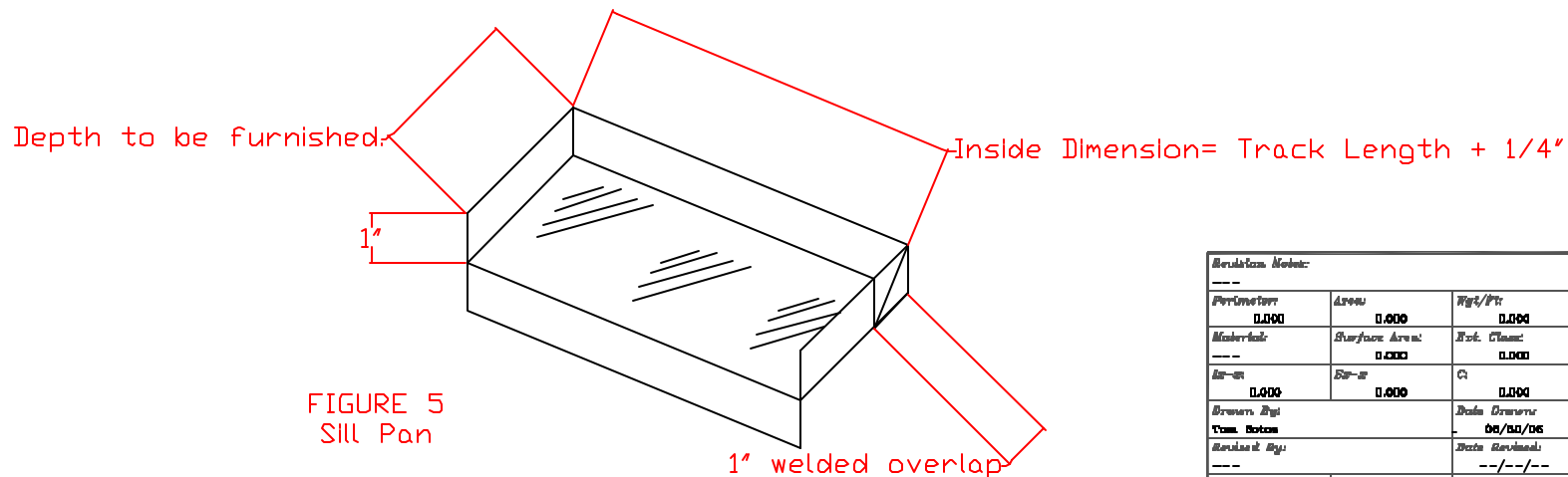

FIGURE 5
Sill Pan

Revision Note: ---			<h1 style="text-align: center;">LAWSON</h1> <p style="text-align: center;">INDUSTRIES, INC.</p> <p style="text-align: center;">MANUFACTURER OF QUALITY ALUMINUM WINDOWS AND GLASS DOORS</p>				B501 N.W. 90 ST. MEDLEY, FLORIDA 33166 PH No. (305) 886-8660		
Perimeter: 0.000	Area: 0.000	Wt./Lb: 0.000							
Material: ---	Surface Area: 0.000	Est. Cost: 0.000	Draw Code: ---		Part Class: ---	Prod. Category: ---	Series/Model: ---	Item: ---	Sheet: 8/8
As-Built: 0.000	Est.-B: 0.000	C: 0.000	FRAME INSTALLATION SLIDING GLASS DOORS						
Drawn By: Tom. Nelson	Date Drawn: 06/01/06		Check Reviewed: --/--/--						
Factor: 000	CDP: 0.000	Scale: 1/8"	Part Number: ---		Drawing Number: ---		Revision Level: ---		

FIELD DIAGNOSIS OF A SLIDING GLASS DOOR INSTALLATION

Before evaluating any sliding glass door installation, you must first examine the corner connection of each jamb to the header and track. Failure to properly pre-assemble the door frame almost guarantees angular, or dimensional faults that are not easily corrected, if detected after stucco and finish plaster.

SIZES

Consult Lawson's web site (www.lawsonwindows.com), finished opening chart, or price book to determine the width and height of the door in question. Measure the unit height, i.e. from top of header to bottom of track. Take measurements at both jambs and at center. All must be the same. Fig. A. Measure width of unit at track, header and at keeper height. All must be the same. Fig.B
If the finished frame has been stuccoed, you can determine the track length by measuring the length of the screen track from weep hole to weep hole. Add 3.0" to that dimension to arrive at track length.

ANGULARITY

The dimension of the assembled frame taken from upper left corner to lower right corner, must be the same as the distance taken from lower left corner to upper right corner. (Measuring from identical starting, and ending points.) This measurement is the most telling of installation failures, and should be accomplished with the assistance of another person to properly position measuring points. Fig. C/D/F Visually examine both jambs. They must face each other squarely. If either jamb, or both jambs do not hold 180 degrees to the opposite wall, the distance between jambs will be either too great or too little to properly accommodate panels. Fig. E

PLUMB:

Place a 6' level against both jambs. If any dimensions taken in Fig. A to Fig. E are not true, they will be further revealed by jamb "Bow-in" or "Bow-out". The placement of a 6' level in addition to proving the straightness of the jamb, also measures its degree of plumb. Fig. F

PANELS:

Consult web site for overall panel widths for the unit in question. Measure width and height of panels in a fashion similar to taking of frame measurements in Fig. A to Fig. D. Check the latching of all panels. Move the nite-lok lever to the off position. Push the thumb-latch down to the unlock position. Move the lock panel out and slightly away from its place in the jamb pocket until it begins to expose its lead edge. Compare the space between the lock stile lead edge and the jamb. View from top to bottom while comparing the reveal between stile edge and jamb. Close and lock all panels. Do they align at interlock, and female stile properly? Are they fully seated into jamb pocket?

WEATHERING

Visually inspect both fixed and moving jamb pockets for presence of weatherstrip. Place 6' level on door track. Is track level, and solidly resting on flat surface? Is the space between the bottom door rail and track consistent from right to left? Is the bottom rail weather-stripping visible, and is it under slight compression against door track? Do panels glide smoothly over door track?

NOTE:

IF DOOR YOU ARE EVALUATING CONSISTS OF CONFIGURATIONS CONTAINING ONE OR MORE FIXED PANELS i.e., OX -XO, OXO, OXXO, OR OXXXXO, BE CERTAIN THAT THE FIXED PANELS HAVE BEEN FULLY SEATED INTO THE JAMB'S FIXED PANEL POCKET. TOO LITTLE PENETRATION INTO THE POCKET WILL RESULT IN FAILURE OF INTERLOCKS TO PROPERLY ENGAGE. SEE FIG. G AND FIG. H. CAN PANELS BE MOVED LATERALLY? ANY SIDE TO SIDE MOVEMENT OF MORE THAN 1/4" ON A 3 PANEL OR 3/8" ON A 4 PANEL UNIT MAY REQUIRE ADJUSTMENTS.

SEALANT AND CAULKING

Refer to Lawson's web site (www.lawsonwindows.com) for detailed information on proper back bedding, face caulking and perimeter caulk of doors, and area of responsibility for various trades.

CAUTION

Industry dimensional tolerance of + or - 1/16" is often compromised due to overlapping conditions. For an extreme example: if the width of the unit is off by + 1/16", and jamb has a + 1/16" deflection and the panels diagonal is off by + 1/16", the compounding of tolerances could create the maximum disadvantage to finding a textbook installation. It should be emphasized that providing a sound structurally secure product is our goal. Reasonable deviation from the ideal is often acceptable as long as the unit measures up to the N.O.A. When you have completed your Sliding Glass Door Installation evaluation, you may find that you are able to take corrective action by movement of the keeper or adjustment of door roller up or down. If however, you have detected flaws in the installation that could possibly require extensive alteration or complete unit removal, it is suggested that you report your findings directly to your branch manager only. Dealer sales personnel should report their findings directly to the dealer sales manager.

The diagrams illustrate various measurement and inspection techniques:

- Fig. A:** Frame elevation showing three horizontal 'Tape Measure' lines across the top and bottom rails.
- Fig. B:** Frame elevation showing two vertical 'Tape Measure' lines along the left and right jambs.
- Fig. C/D/F:** Frame elevation showing a diagonal 'Tape Measure' line from the top-left to the bottom-right corner, and a vertical 'Level Frame Jamb' line on the right side.
- Fig. E:** Close-up of the jamb connection showing a 90-degree angle between the jamb and the header.
- Fig. G:** Close-up of the jamb connection showing a 2-inch 'Clip' and a 'Fixed Stile'.
- Fig. H:** Close-up of the jamb connection showing the internal track and roller assembly.

PERIMETER 0.000 0.000 0.000			LAWSON INDUSTRIES, INC. 8501 N.W. 90 ST. MEDLEY, FLORIDA 33166 PH No. (305) 884-8880						
MATERIAL 0.000 0.000 0.000			MANUFACTURER OF QUALITY ALUMINUM WINDOWS AND GLASS DOORS						
DRW 0.000	REV 0.000	CL 0.000	Drawn By ---	Part Class ---	Prod. Category ---	Series/Model ---	Item ---	Sheet 1/1	
DATE 01/11/07			SLIDING GLASS DOOR FIELD DIAGNOSIS						
Factor 000			Scale 0.000			Part Numbers ---		Drawing Number ---	Revision Level ---

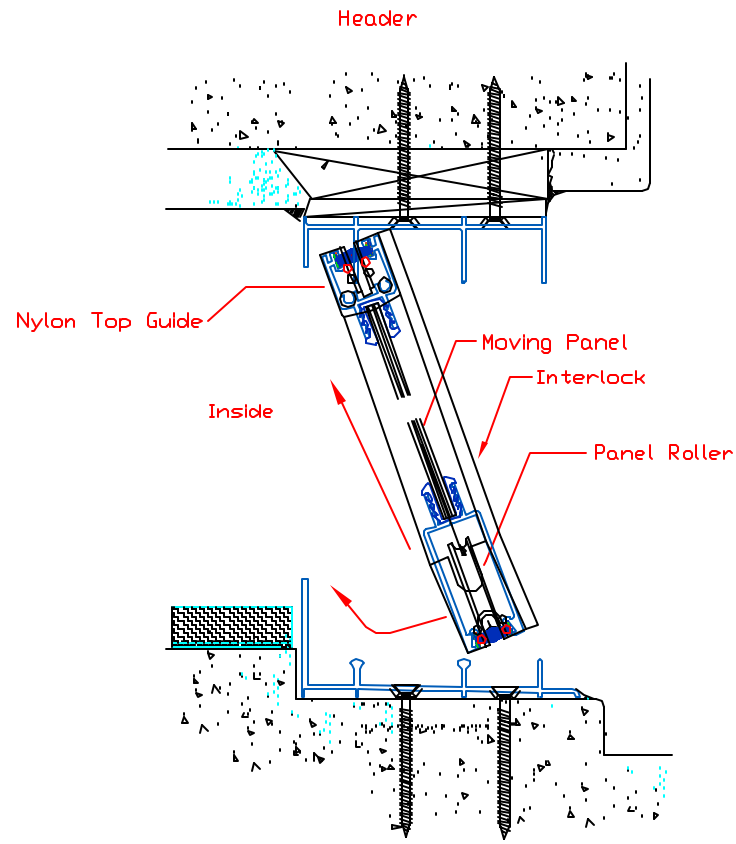

FIGURE 1

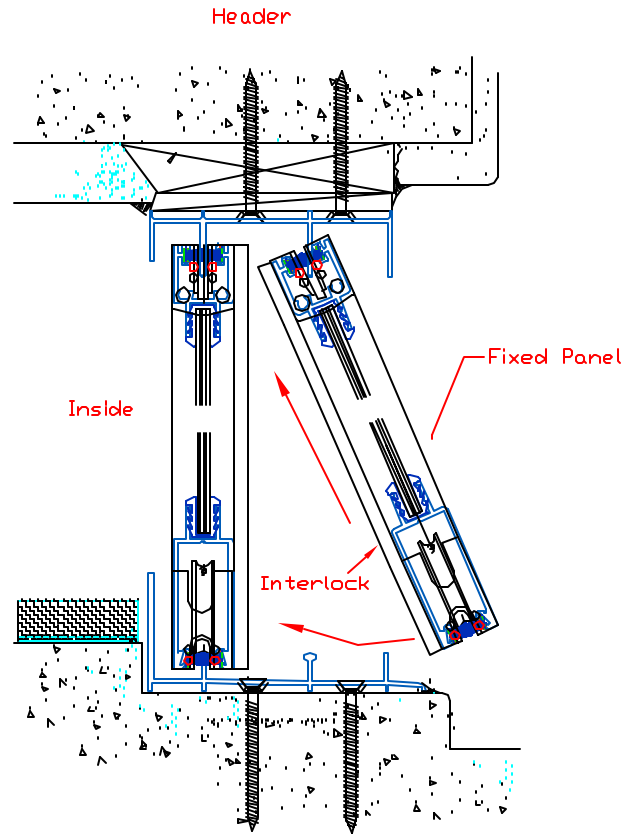

FIGURE 2

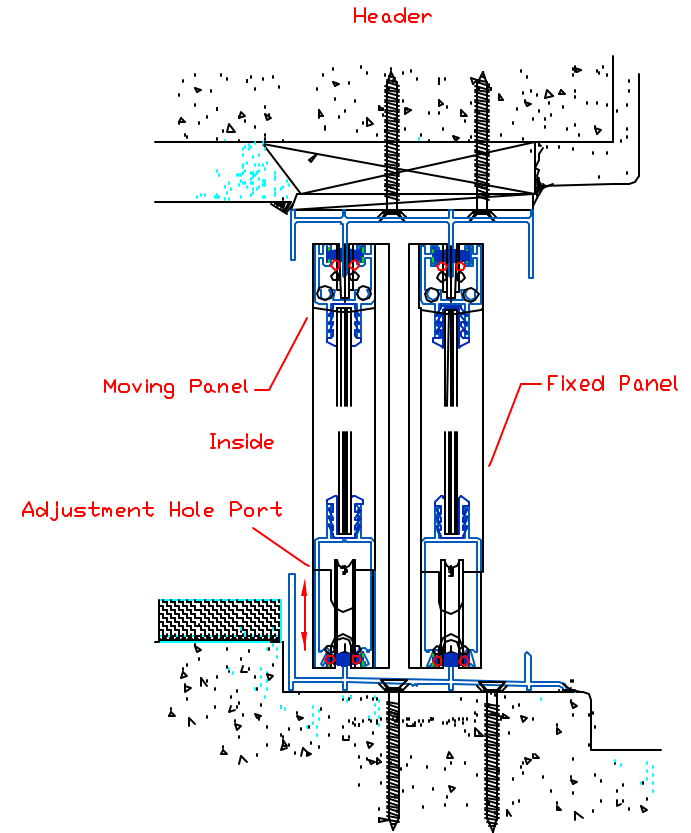

FIGURE 3

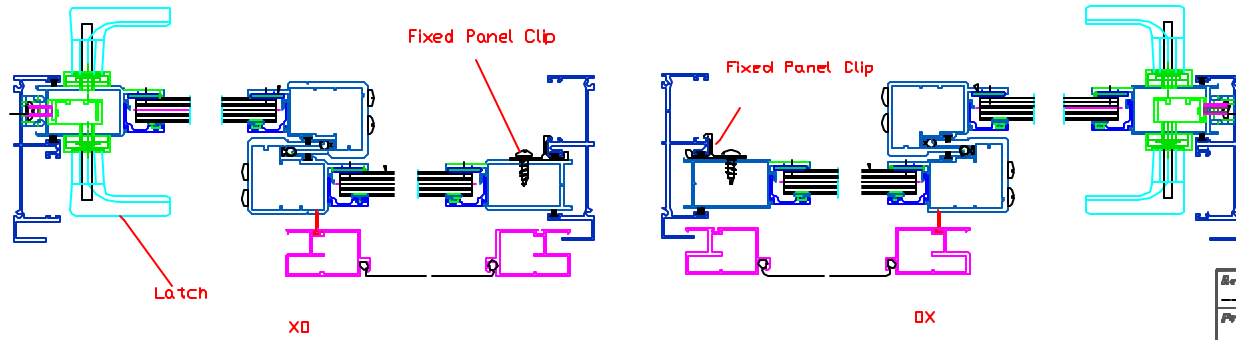

FIGURE 5 A and B

Revision Note:	
Perimeter	0.000
Material	---
As-sh	0.000
Drawn By	---
Time	---
Factor	000
Area	0.000
Surface Area	0.000
Est. Cost	0.000
Est. -a	0.000
Drawn Date	06/01/06
Check Date	---
Scale	1:1

LAWSON
INDUSTRIES, INC.

B501 N.W. 90 ST.
MEDLEY, FLORIDA 33166
PH No. (305) 886-8660

MANUFACTURER OF QUALITY ALUMINUM WINDOWS AND GLASS DOORS

Drawn	Checked	Prod. Category	Series/Model	Item	Sheet
---	---	---	---	---	1/2

SLIDING GLASS DOOR PANEL INSTALLATION Page 1/2

Part Number	Drawing Number	Revision Level
---	---	---

PANEL INSTALLATION

A - Clean door tracks of all sand, dirt and debris.

B - If tracks have not been previously anchored, do so at this time. Before insertion of tapcon into all coined frame installation holes, fill holes with caulk. Take special care to run tap-cons fully home. Heads of tap-cons must be flush with flat of track.

C - Inspect all frame installation holes for presence of fasteners. Seam seal all naked tap-con heads in jambs, and tracks.

D - Check joint of jambs to track for presence of seam sealer. Pay particular attention to upstanding track riser which must be in perfect contact with inside leg of jamb. Riser leg must be sealed to inside leg of jamb.

PANEL CONFIGURATION CODE

XO or OX = One moving panel (X) and one fixed panel (O).

OXO = Fixed, moving, fixed on two tracks.

OXXO = Fixed, moving, moving, fixed on two tracks.

OX or XO

1 - Select locking panel which will be first paned to install on the inside track. Interlock hook must face to exterior.

2 - Raise panel up. Nylon guide in top of panel must straddle header's interior fin. See fig. #1

3 - While pushing panel up into top of header, swing bottom of panel to inside, and carefully lower panel so that roller in bottom rail sits on inside track runner. See fig.# 2

4 - Install fixed panel as in steps #1 and #2. Lower fixed panel so that boot in bottom rail sits on outside track runner.

5 - Raise each side of moving panel up to relieve panel's weight on track runner. remove nylon access hole plug in side of moving panel bottom rail. Insert phillips head screw driver into hole, and turn clockwise to raise, and counterclockwise to lower. Attempting to adjust roller without relieving weight of panel on runner may cause adjusting screw to strip threads in roller housing. Panel must roll smoothly, and be plumb when aligned with jamb. Fig. # 3.

6 - Adjust jamb keeper to allow for sure easy latching. Keeper can be raised or lowered by loosening both keeper screws. When satisfactorily adjusted, make final check for plumb alignment at jamb.

Should door not latch by adjusting keeper, take the following action:

A - Turn slotted head screws in face of mortise lock which alters the throw of the latch bolt. See fig. # 6

B - If latch continues to defy adjustment, revert back to adjusting panel height.

C - Activate thumb turn to lock panel. See fig.# 4

7 - Place 4 jamb fixing clips (part #23) into fixed jamb pockets. Engage clips with backside of jamb pocket. Rotate clips until they lock into place. See fig. #5a

8 - Push fixed panel into pocket until it resists further movement. Secure clips to fixed stile using #10x5/8 sms.

9 - Open and close moving panel to test operation.

10- Refer to 9200 series retainer clip installation practice.

OXO and OXXO

The rules for installing XO will apply to OXO and OXXO. Additional panels i.e. female (astragal) panel must align with locking panel with clean even reveal. female panel is also adjustable and it may be necessary to also adjust panel to plumb with locking panel. See fig. # 7.

Minimal clearance exists between female stile at top and bottom and track riser. Check riser for any indication that it has been bent or deformed during construction, which will cause interference when moving panel. If riser position cannot be corrected, it may be necessary to trim the inside leg of female stile to allow panel to move freely.

11- Refer to N.O.A. and fixed retainer clip installation for proper placement of clips and fasteners.

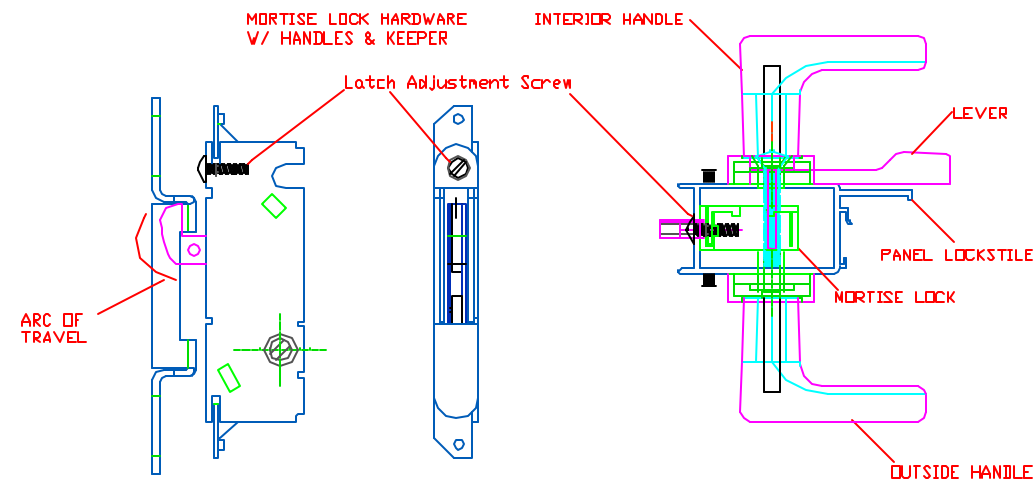
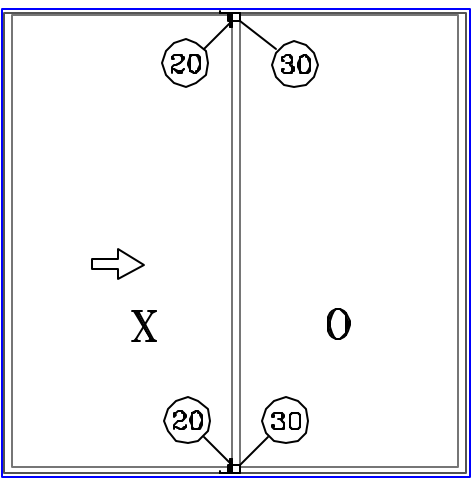
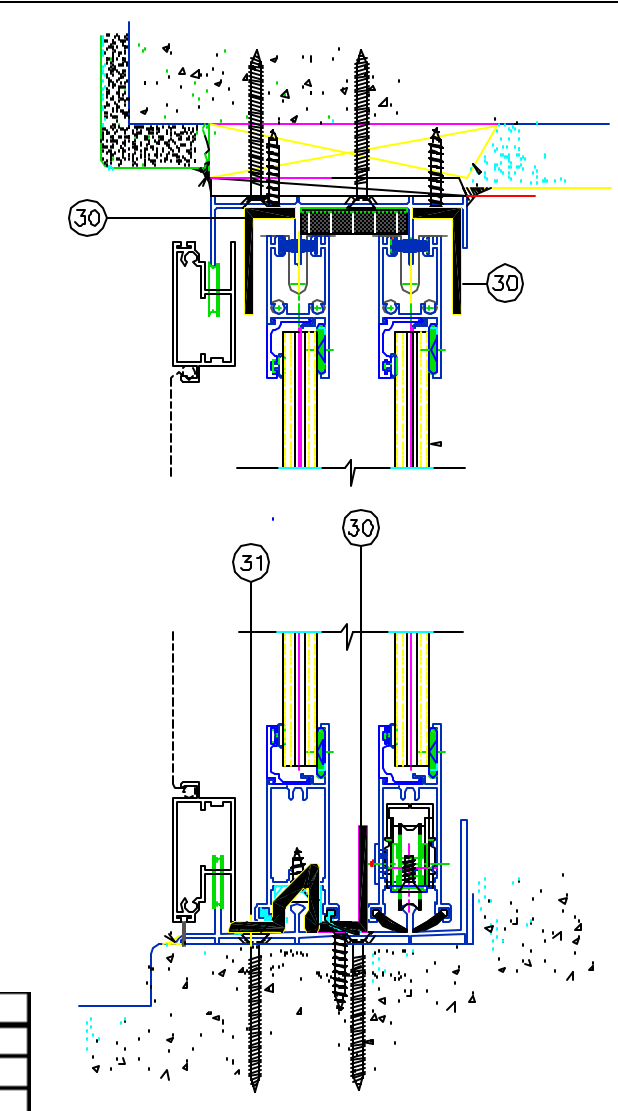
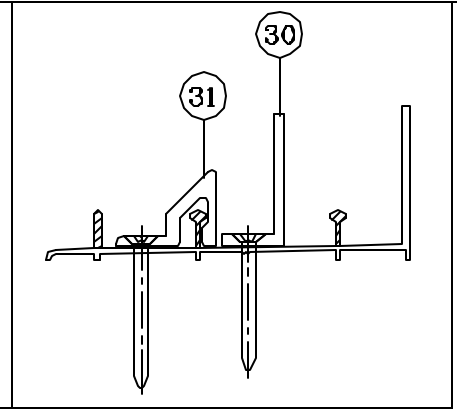
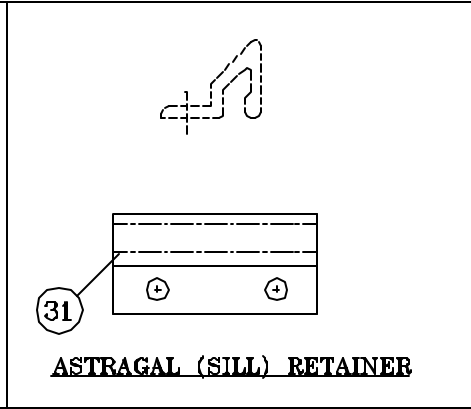
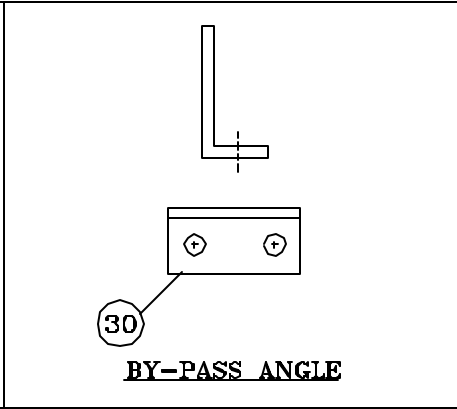
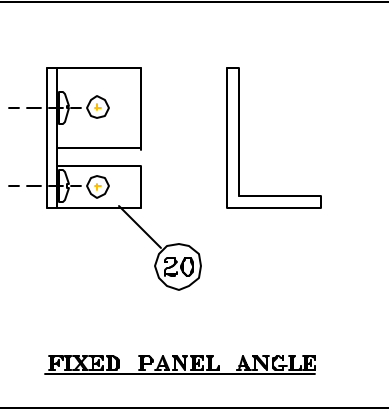
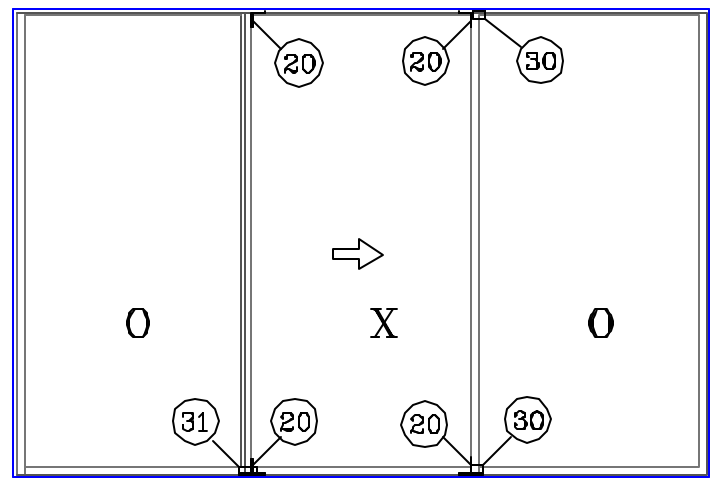

FIGURE 6

Revision Note: ---			<h1 style="margin: 0;">LAWSON</h1> <h2 style="margin: 0;">INDUSTRIES, INC.</h2> <p style="margin: 0; font-size: small;">MANUFACTURER OF QUALITY ALUMINUM WINDOWS AND GLASS DOORS</p>				B501 N.W. 90 ST. MEDLEY, FLORIDA 33166 PH No. (305) 886-8660	
Perimeter	Area	Wt./Lb.	Draw Code	Part Class	Prod. Category	Series/Model	Form	Sheet
0.000	0.000	0.000	---	---	---	---	---	8/8
Material	Surface Area	Inst. Class	<h3 style="margin: 0;">SLIDING GLASS DOOR PANEL INSTALLATION Page</h3> <h3 style="margin: 0;">2/2</h3>					
---	0.000	0.000						
In-in	Sq-ft	Ct.						
0.000	0.000	0.000						
Drawer Qty	Date Drawn							
---	06/01/06							
Revised Qty	Date Revised							
---	--/--/--							
Factor	Code	Scale	Part Number	Drawing Number			Revision Level	
000	0.000	1/8"	---	---			---	



TWO DOOR / TWO TRACK



THREE DOOR / TWO TRACK

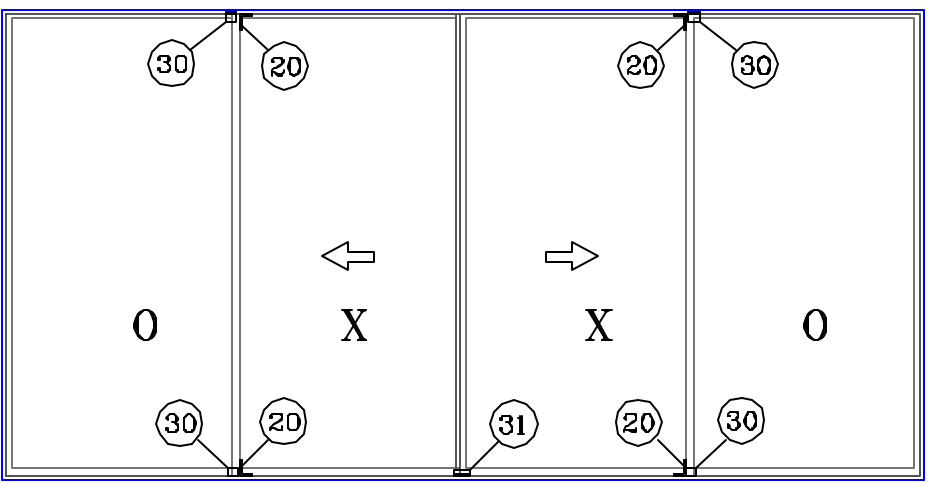

FOUR DOOR / TWO TRACK

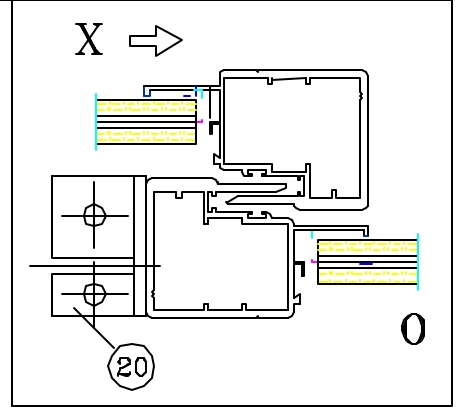

# Clips	#20	#30	#31
XO-OX	2	2	0
OXO	4	2	1
OXXO	4	4	1

IMPACT SLIDING GLASS DOOR CLIP INSTALLTION

Revision Table		<p>8501 N.W. 80 ST. MEDLEY, FLORIDA 33186 PH No. (305) 886-8880</p> <p>MANUFACTURER OF QUALITY ALUMINUM WINDOWS AND GLASS DOORS</p>				
Drawn By:	TR Sotao					Part Status:
Checked By:		Prod. Date:	8.2.0	Series/Model:	9200	1 of 1
Approved:		Part Number:	SGD-9200 IMPACT SLIDING GLASS DOOR CLIP INSTALLATION DETAILS			
Supervisor:		Scale:	1:1	Drawing Packer:	Revision Level:	

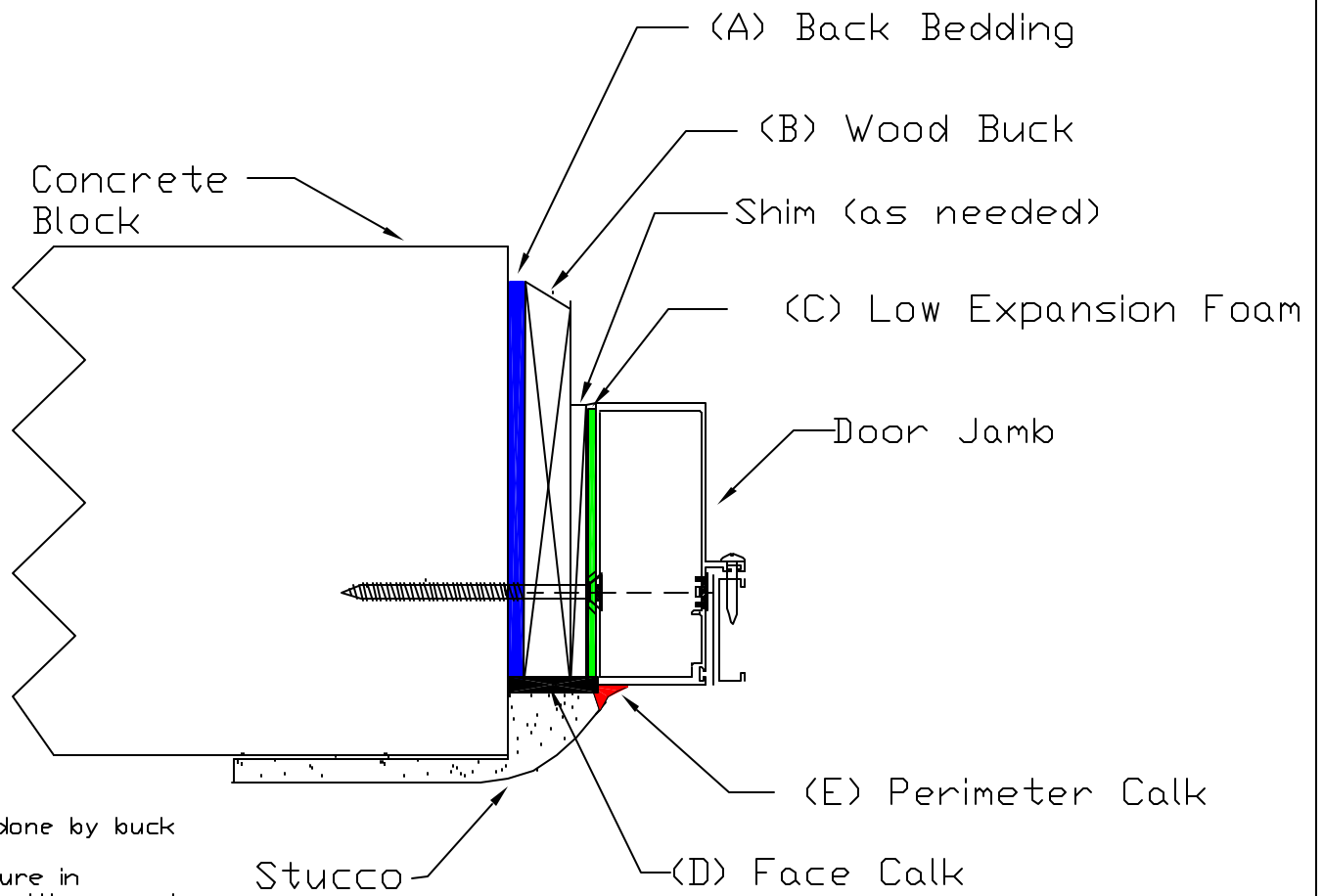

- (A) Back bedding of jamb buck to block is done by buck installer.
- (B) Wood Buck must be anchored to structure in accordance with trade practice, and comply with governing building code. Bottom end of wood buck MUST BE $\frac{1}{2}$ " ABOVE TOP of interior concrete floor. Buck NEVER extends down into depression.
- (C) Any VERTICAL space between door and jamb and jamb and buck is to be filled with a low expansion foam. (not by door installer). The cavity between the block wall and BOTTOM of door jamb must be filled with a polyurethane or equal material.
- (D) Face caulk using a urethane or equal material must extend from jamb to block. (not by window installer)
- (E) Perimeter caulk protects seam where stucco meets jamb or door. (not by window installer)

Commercial tolerances apply unless noted otherwise.
 Notched wall thickness 1/2" or less unless noted otherwise.
 Blank sheets between 4.015 unless noted otherwise.

Structure Notes: Partitions: 0.000 Material: 0.000 Co-ty: 0.000 Frame Sp: Tom Sotos Finished Sp: --- Finish: 000				Dimensions: Area: 0.000 Perim Area: 0.000 Sh-w: 0.000 Sh-h: 0.000 Sh-h: 0.000 Sh-h: 0.000 Sh-h: 0.000				Lawson Industries, Inc. 8501 N.W. 90 ST. MEDLEY, FLORIDA 33108 PH No. (305) 898-8800 MANUFACTURERS OF QUALITY ALUMINUM WINDOWS AND GLASS DOORS			
Glass Type: --- Glass: --- Glass: --- Glass: --- Glass: ---				Panel Glass: --- Panel Glass: --- Panel Glass: --- Panel Glass: --- Panel Glass: ---				GENERIC DOOR WATERPROOFING PRACTICE			
Part Number: XXXXX				Drawing Number: XX-XX-XX				Revision Code: ---			